

CTMB SERIES USERS MANUAL



HBCONTROLS 50A, TIME PROPORTIONING, CURRENT MONITORING, SSR MONITORING, POWER CONTROLLER



TABLE OF CONTENTS

1. Ordering Codes..... 2

2. Description 2

 2.1 Features..... 3

3. Installation 3

 3.1 Mounting Instructions 3

 3.2 Electrical Connections..... 3

4. Operation 4

 4.1 Power Supply 4

 4.2 24V Power Fusing..... 4

 4.3 I/O Isolation..... 4

 4.4 0-10V Current Output..... 4

 4.5 SSR Input Cycle Times 4

 4.6 Current Setpoints 5

 4.6.1 Procedure for Setting the Current Window 5

 4.7 Shorted SSR Detection 6

 4.8 Load Types 6

 4.9 Status LEDs and Relay Contacts 6

 4.10 Timing 6

 4.10.1 Startup Timer 7

 4.10.2 Fault Delay..... 7

 4.11 WIRING DIAGRAMS 7

5. Electrical Specifications 7

6. Mechanical Dimensions 8

7. Contact Information..... 10

1. Ordering Codes

Part#	Description
CTMB	Current Monitor 1-50A
CTMB-90HDL	Current Monitor, SSR, 50A Heat Sink SSR Assembly
CTMB-90HDL-2	(3 Phase, 2 Pole)
CTMB-90HDL-3	(3 Phase, 3 Pole)
CTMBV-90HDL	Current Monitor, Time Prop. Board, 50A Heat Sink SSR Assembly
CTMBV-90HDL-2	(3 Phase, 2 Pole)
CTMBV-90HDL-3	(3 Phase, 3 Pole)

2. Description

The CTMB is a Current Monitor designed for use with standard footprint SSRs (Solid State Relays). The module mounts directly on the SSR's input screws. The module operates by monitoring the current on the SSR'S output to detect if the current has dropped below or exceeded preset user values. This is valuable for detecting the loss of partial load, full load, power, shorted SSR, etc.

2.1 Features

- Over and under current detection
- LED indication of fault type
- Normally closed relay contact output
- 0-10V current level output (proportional output)
- Small module mounts on the input terminals of an SSR

3. Installation



WARNING: FIRE HAZARD!! Even quality electronic components **CAN FAIL KEEPING FULL POWER ON!** Provide a **SEPARATE (redundant) OVER TEMPERATURE SHUTDOWN DEVICE** to switch the power off if safe temperatures are exceeded. (Consult HBCcontrols for proper selection)



WARNING: HIGH VOLTAGE!! This control is installed on a Solid State Relay with high voltage on it. This control must be installed in a **GROUND**ED enclosure by a qualified electrician in accordance with applicable local and national codes including NEC and other applicable codes. Provide a safety interlock on the door to remove power before gaining access to the device.

3.1 Mounting Instructions

The CTMB mounts directly to the control input terminals of an SSR. Some relays have short input screws and longer screws will be required to reach through the contacts on the CTMB. Be sure to observe the correct polarity when mounting the module (module should be positioned over the SSR). The module should sit firmly on top of the SSR when the screws are tightened.

3.2 Electrical Connections



See the WIRING DIAGRAMS at the end of this document. Make sure the module ordered is the correct module for the application before wiring.

4. Operation

4.1 Power Supply

The CTMB power requirement is 24V AC +/-20% 47-63Hz or 24VDC +40%/-10%. The Current draw is 50mA nominal.

4.2 24V Power Fusing

Fusing may be accomplished by fusing each module separately or fusing groups of the modules with either primary or secondary fusing. The current draw of each CTMB is 50mA max.

4.3 I/O Isolation

The control input is optically isolated from the power supply input and 0-10V outputs. The 0-10V shares a common ground with the power supply input. The relay contacts are isolated from all of the other I/O lines.

4.4 0-10V Current Output

The CTMB has a 0-10Vdc output that is proportional to the current level on the output of the SSR. The 0-10V output will drop to 0V when the SSR is turned off. The 0-10V output has a high output impedance designed for monitoring with a chart recorder, DVM or Data logging device.

4.5 SSR Input Cycle Times

The minimum recommended cycle time of the controller cycling the CTMB is one second. Performance is improved at longer cycle times. The minimum on-time that the control must provide for accurate current detection is approx 30mS. This is to allow for adequate sampling of the 50 or 60Hz line.

A Shorted SSR cannot be detected with the SSR full on. The minimum off-time required for shorted SSR detection is 50mS.

Note that at low duty cycles the CTMB's internal filtering will take longer to "charge up" and will result in a longer delay in the response time.

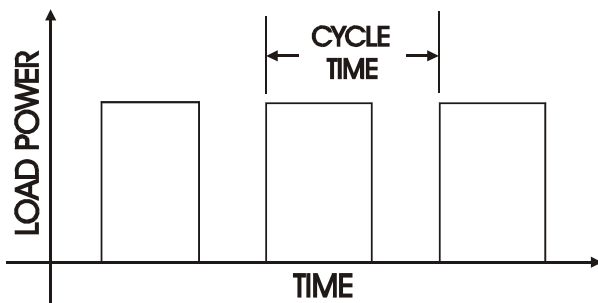

4.6 Current Setpoints

The CTMB has high and low current setpoint potentiometers that are used to create an acceptable current window for “OK” status to be maintained.

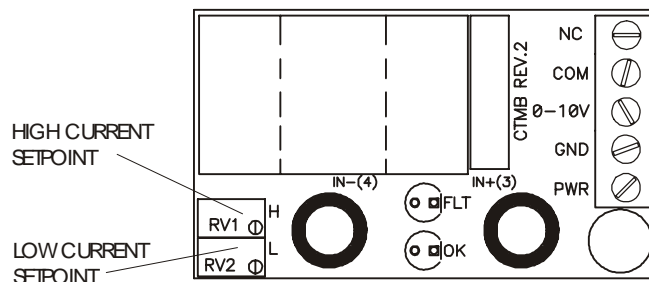

If the measured current exceeds the high current setpoint, the relay terminals NC-COM will open.

If the measured current drops below the low current setpoint, the relay terminals NC-COM will open.

4.6.1 Procedure for Setting the Current Window

With the CTMB wired per the WIRING DIAGRAMS section and the SSR driving the load:

- 1) Set the high current pot fully CW until it clicks
- 2) Set the low current pot fully CCW until it clicks
- 3) The green OK LED should be energized.
- 4) Turn the low current pot slowly CW until the red Fault LED blinks slowly. Now turn it back CCW by a factor of ~3 amps per turn until the desired window is achieved. (Note: if the window is set too small the relay may trip due to normal system fluctuations.)
- 5) Turn the High current pot slowly CCW until the red Fault LED blinks fast. Now turn it back CW by a factor of ~3 amps per turn until the desired window is achieved.

6) The green OK led should be on and the window should now be set.

4.7 Shorted SSR Detection

A shorted SSR is determined to have occurred if the load current present when the SSR is off is greater than 25% of the current when the SSR is on. This allows detection of both full and half wave failure modes of the SSR.

4.8 Load Types

The CTMB is designed for operation with resistive heating loads. High inrush loads present a unique set of circumstances for current detection when the load is being cycled because a measurable current spike will be present with each on cycle. The current setpoint pots should be set during the nominal duty cycle on high inrush loads. The CTMB is not recommended for use with inductive or motor loads.

4.9 Status LEDs and Relay Contacts

The CTMB has two LEDs to indicate status:

Condition	OK LED (GREEN)	Fault LED (RED)	Relay Contacts (NC-COM)
Current in detection window	ON	OFF	Closed
Under Current (or open load)	OFF	Slow Blinking (2Hz)	Open
Over Current	OFF	Fast Blinking (8Hz)	Open
Shorted SSR	OFF	ON Steady	Open

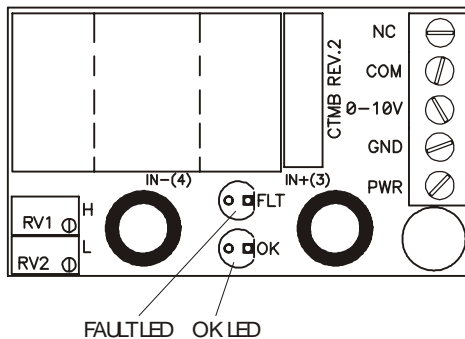

4.10 Timing

4.10.1 Startup Timer

The CTMB has a startup timer that keeps the CTMB in the “OK” state on power up regardless of system conditions until approx 6 seconds have elapsed. This is to allow all of the control system components to initialize prior to detection.

The CTMB is held in the OK state until the control input is turned on because the current cannot be measured until the SSR is turned on.

4.10.2 Fault Delay

A fault condition must be present for ~3 seconds for the CTMB to react to it. Note that at low duty cycles the CTMB’s internal filtering will take longer to “charge up” and will result in a longer delay in the response time.

4.11 WIRING DIAGRAMS

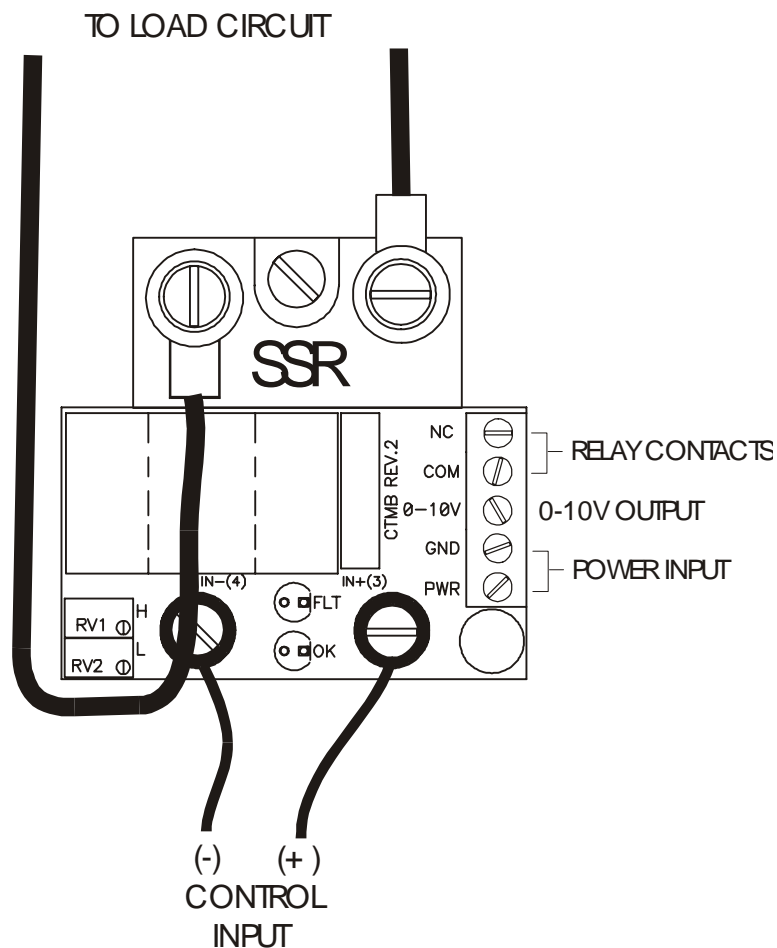

5. Electrical Specifications

Current Detection Range	1 – 50Amps
Relay Output	250mA max / <100VDC
Response Time to Fault	~3 Seconds for over/under current (SSR full on) ~3 Seconds for shorted SSR (SSR full off)
Response Time to OK	~250mS
Input Cycle Time Range	1 Second min.
Minimum Control Input On Time	30mS for proper current detection
Minimum Off Time	50mS for shorted SSR detection
Ambient Temperature Range	0 to 60 °C
Power Supply	24V AC +/-20% 47-63Hz or 24VDC +40%/-10% 50mA max.
Line Frequency Range	47-63 Hz

6. Mechanical Dimensions

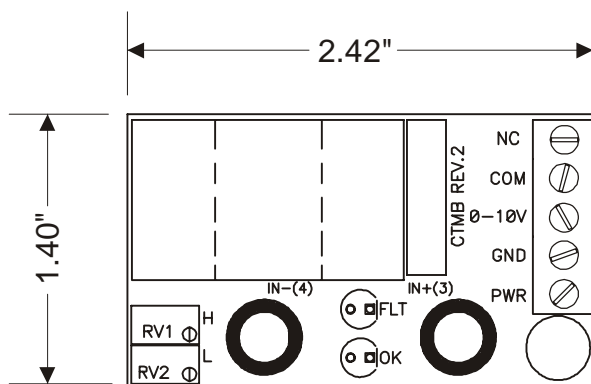

Max Height is 1.6"

CTMB Assemblies:

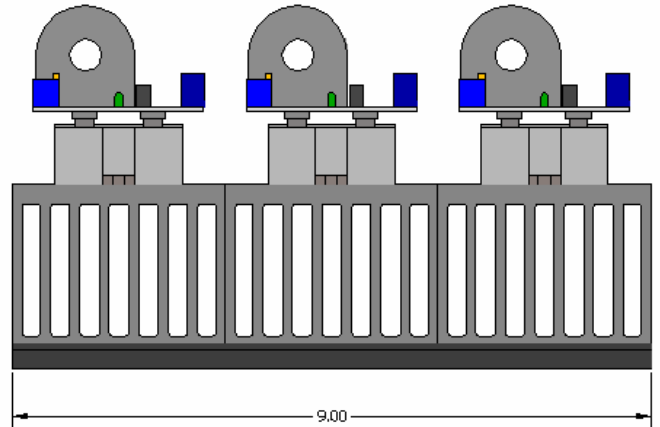
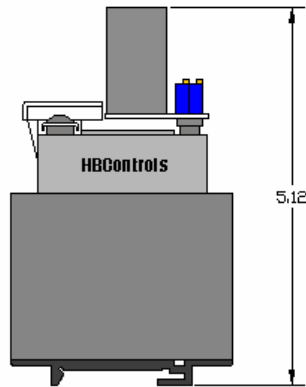
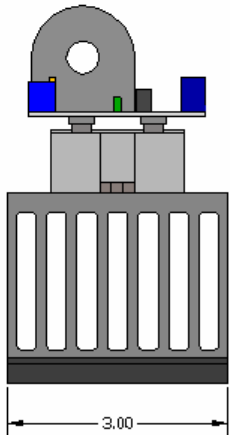
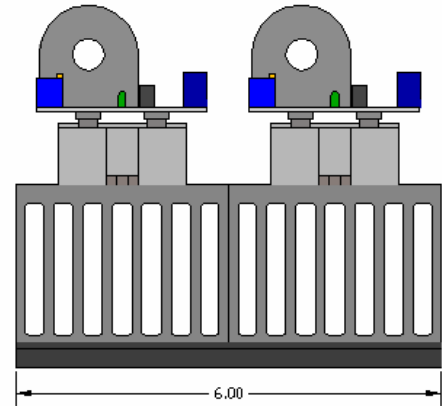

CTMBV Assemblies:

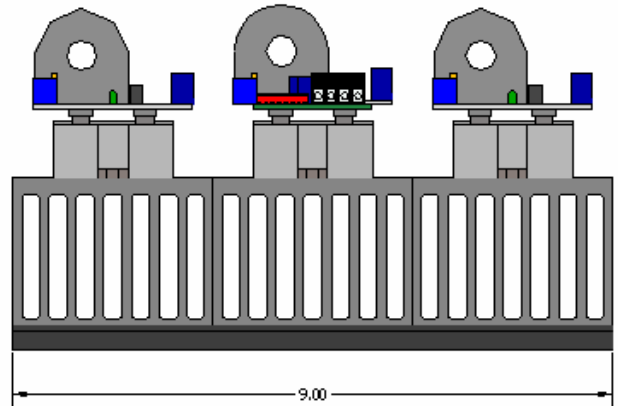
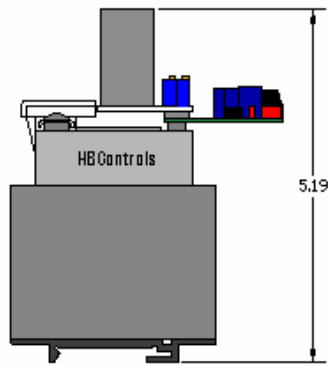
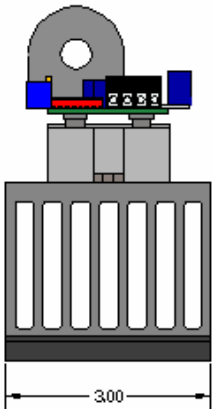
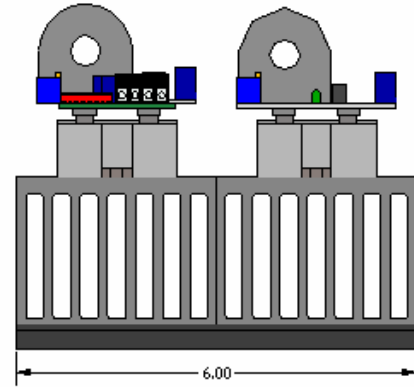
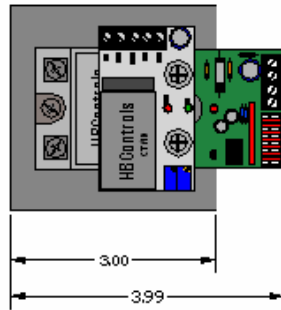

7. Contact Information

HBCcontrols
 221 Weaver St.
 Fall River, MA
 02720
 Tel: 508-676-7345
 Fax: 508-676-7346
 www.HBCcontrols.com